

# Corner Chair Measurement

Special Needs Solutions  
(520) 838-0987  
snsarizona@gmail.com

Date: \_\_\_\_\_

Person: \_\_\_\_\_

- A – From seat to top of shoulder.
- B – From seat to armpit.
- C – From seat to bottom of elbow held at 90 degrees.
- D – From bottom of child's shoe to crease at back of knee.
- E – From back of seat to crease at back of knee.
- F – Length of shoe.
- G – Belly circumference.
- H – Chest circumference.
- I – Shoulder width.

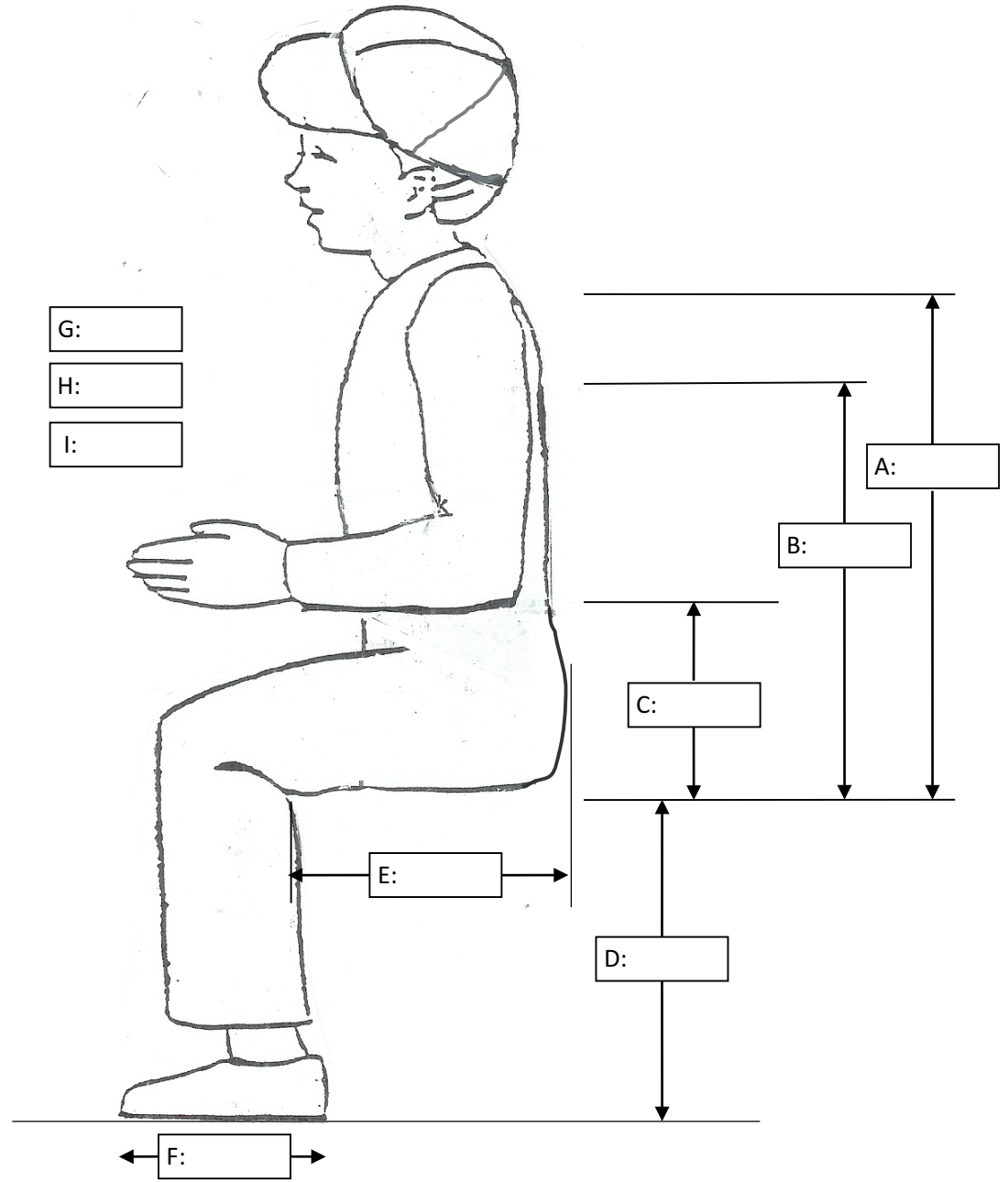

# Corner Chair and Table

Special Needs Solutions (520) 838-0987 snsarizona@gmail.com

Person: \_\_\_\_\_ Date: \_\_\_\_\_  
Referred: \_\_\_\_\_ Invoice: \_\_\_\_\_  
Contact: \_\_\_\_\_  
Bill To: \_\_\_\_\_

1" Padding - Color: \_\_\_\_\_

Seat Belt? \_\_\_\_\_

Chest Strap? \_\_\_\_\_

Abductor? \_\_\_\_\_

Foot Plate? \_\_\_\_\_ Feet on Floor? \_\_\_\_\_

Table? \_\_\_\_\_

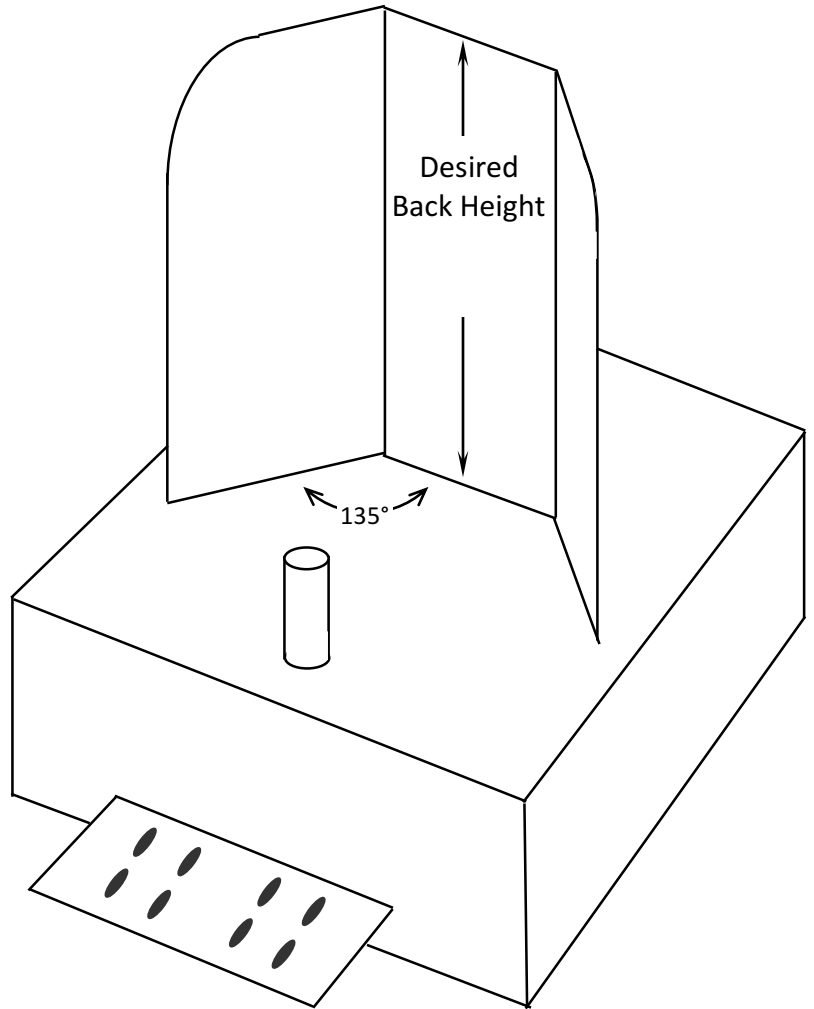
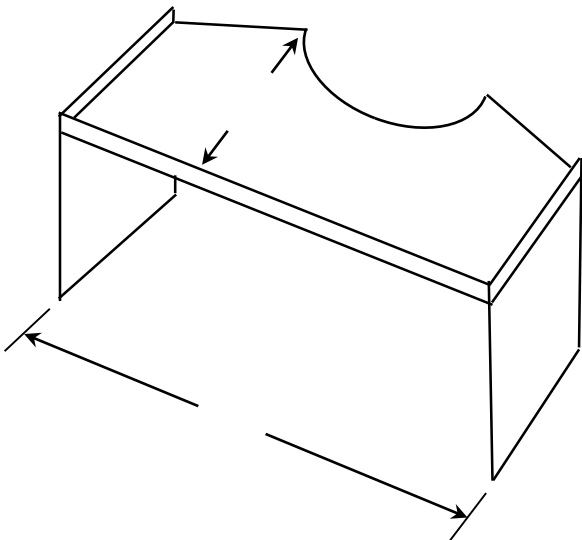

Special Instructions:

\_\_\_\_\_  
\_\_\_\_\_